



FiltoClear 12000/16000/20000/30000

DE	Gebrauchsanleitung
GB	Operating instructions
FR	Notice d'emploi
NL	Gebruiksaanwijzing
ES	Instrucciones de uso
PT	Instruções de uso
IT	Istruzioni d'uso
DK	Brugsanvisning
NO	Bruksanvisning
SE	Bruksanvisning
FI	Käyttöohje
HU	Használati útmutató
PL	Instrukcja użytkowania
CZ	Návod k použití
SK	Návod na použitie
SI	Navodila za uporabo
HR	Uputa o upotrebi
RO	Instrucțiuni de folosință
BG	Упътване за употреба
UA	Посібник з експлуатації
RU	Руководство по эксплуатации
CN	使用说明书



Ⓐ

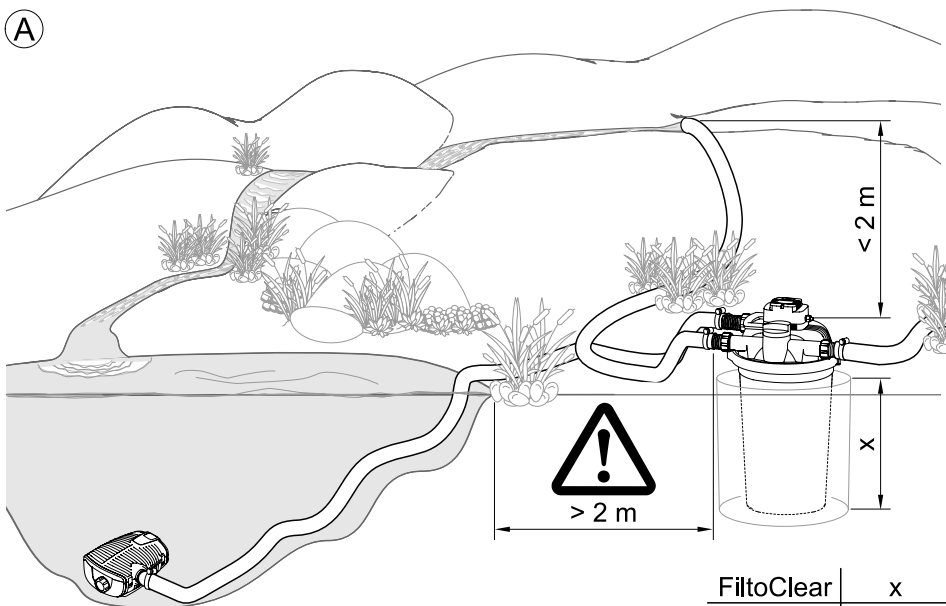

FiltoClear	x
12000	0.24m
16000	0.36m
20000	0.48m
30000	0.48m

Ⓑ

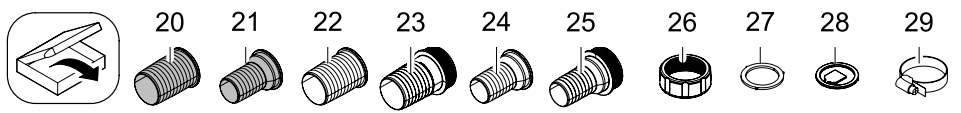
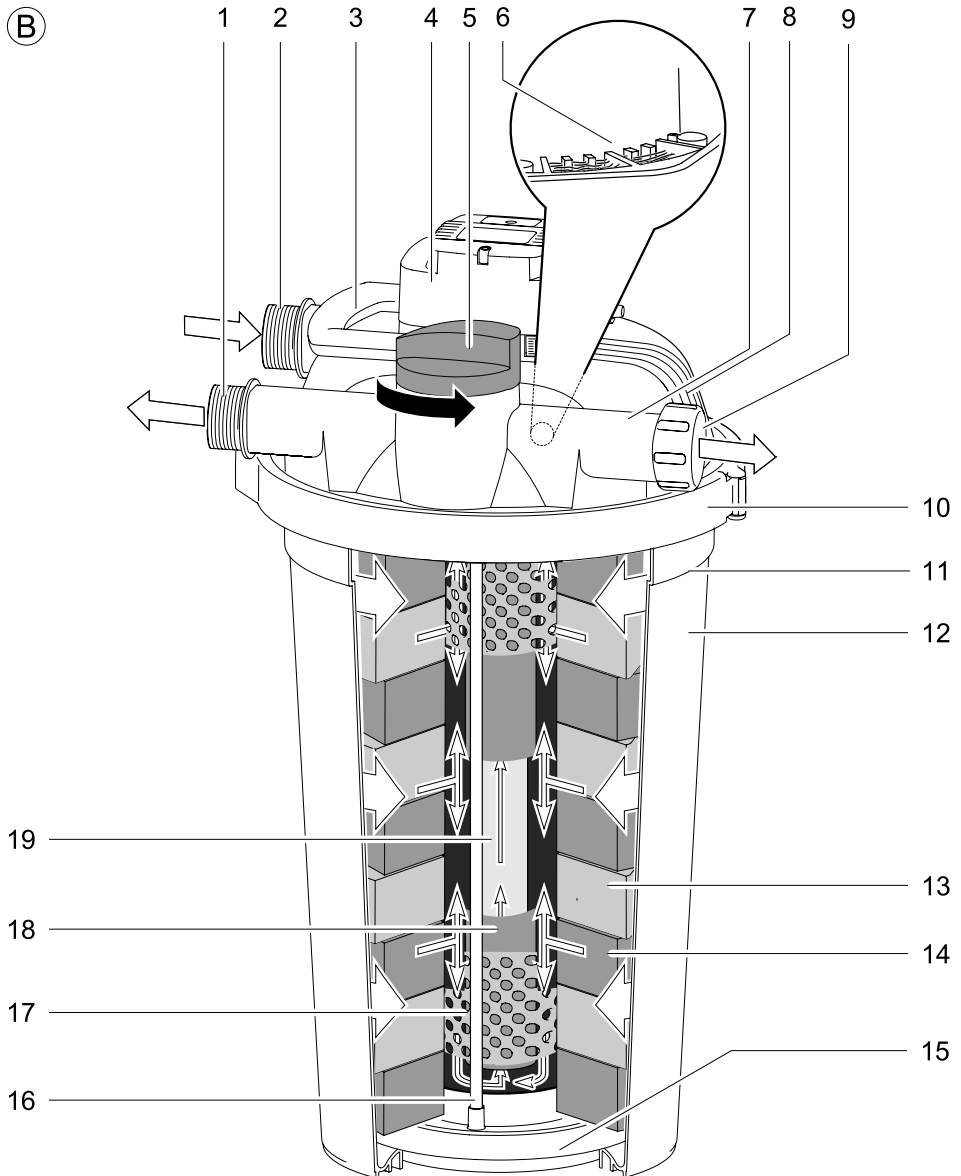

©

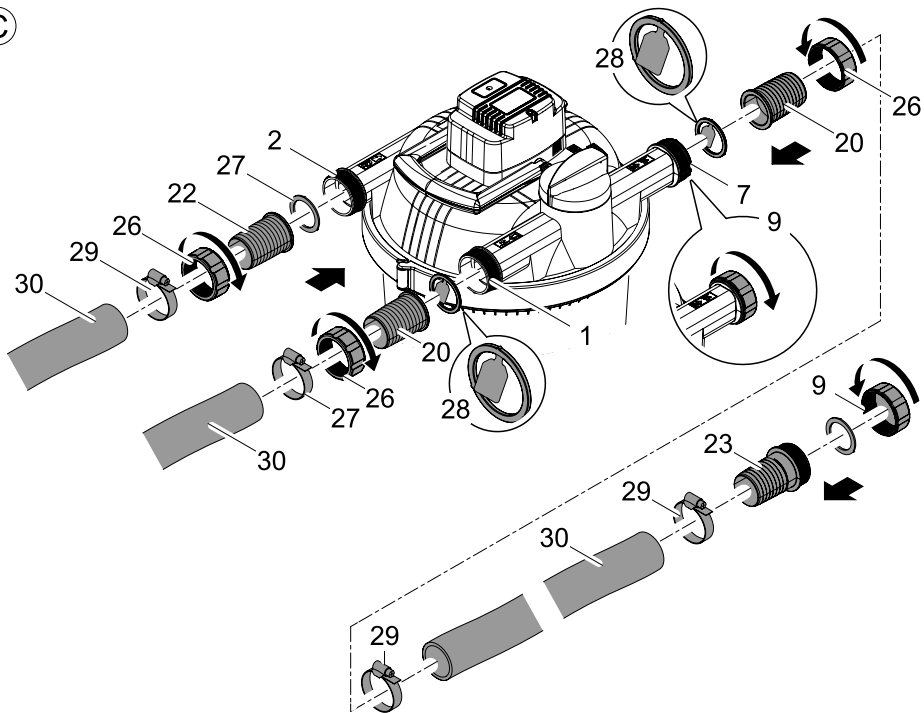

©

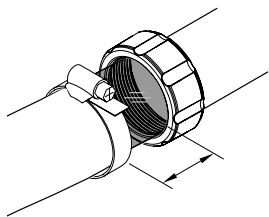

©

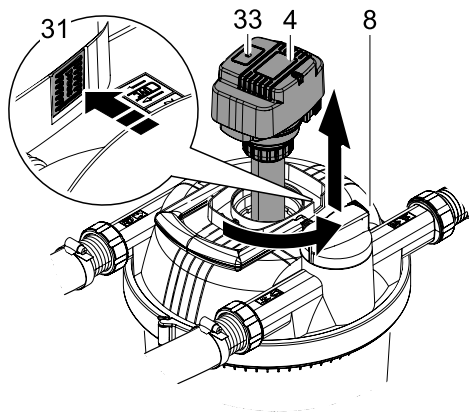

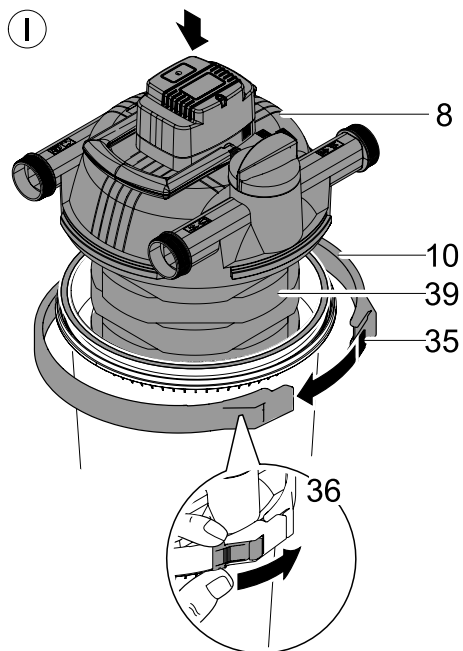
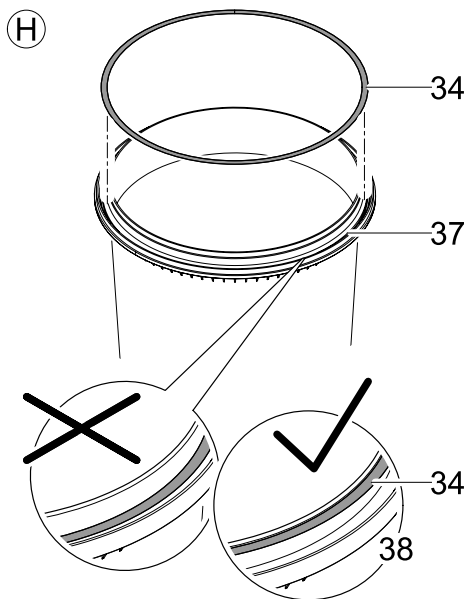
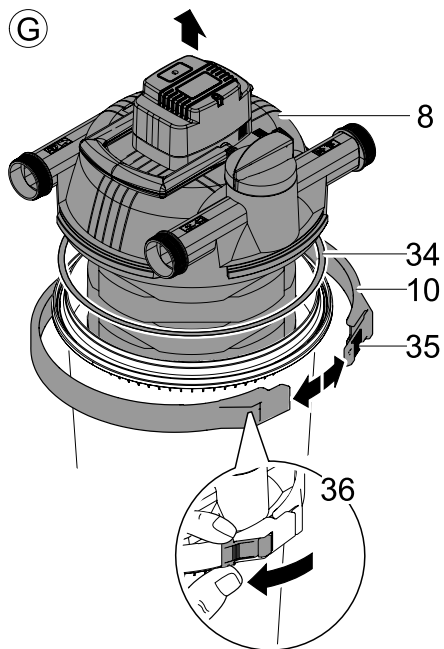
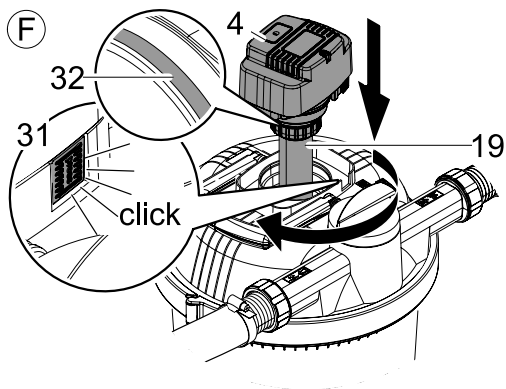

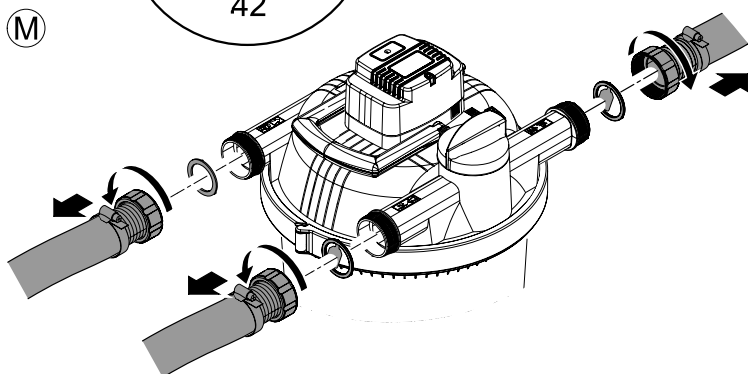
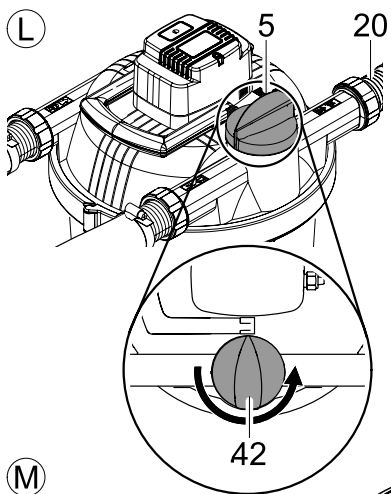
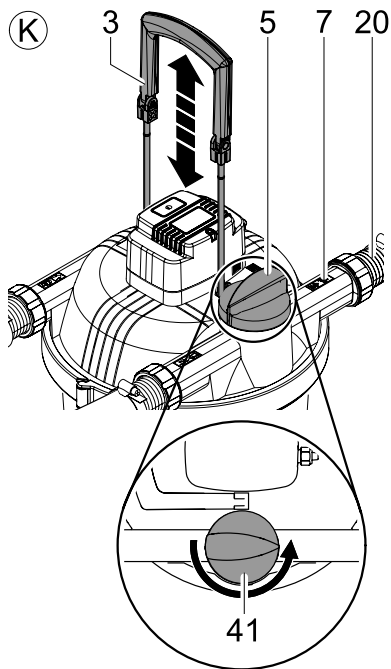
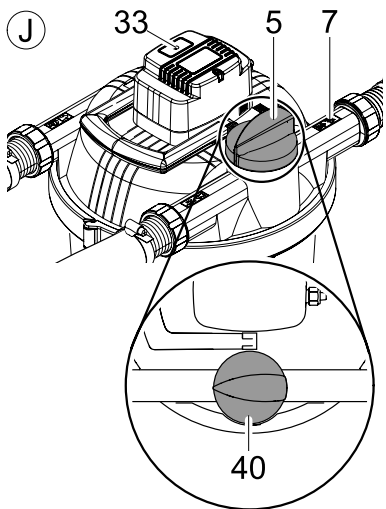

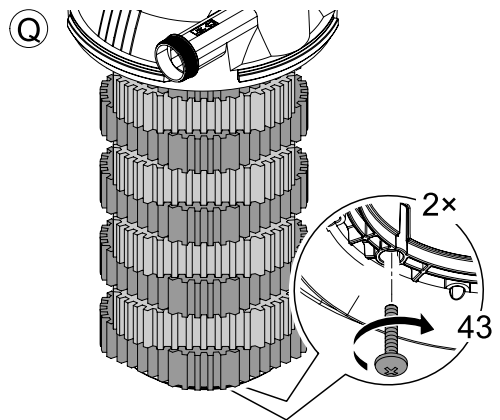
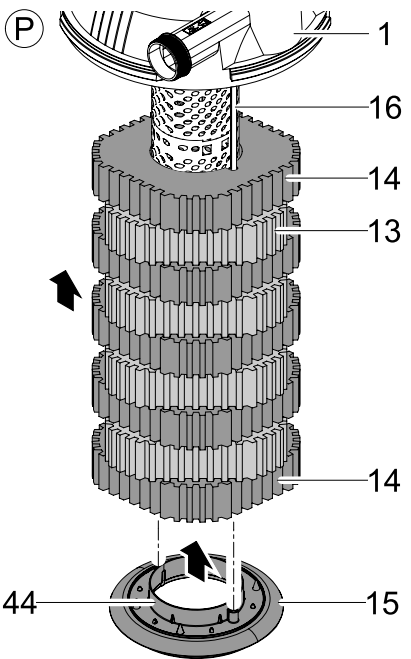
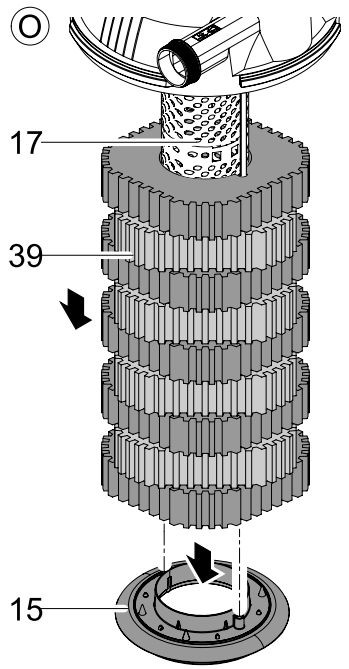
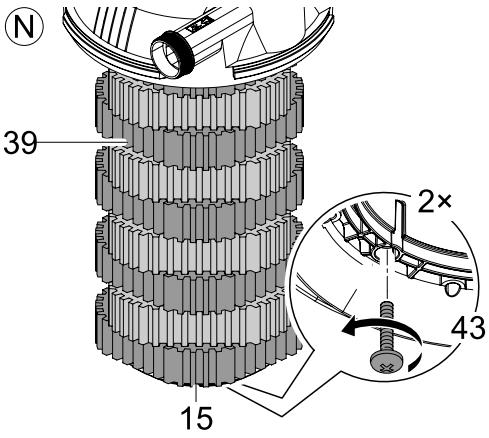

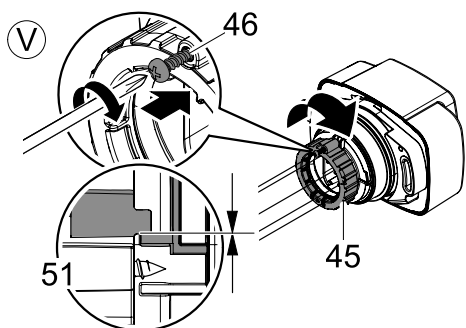
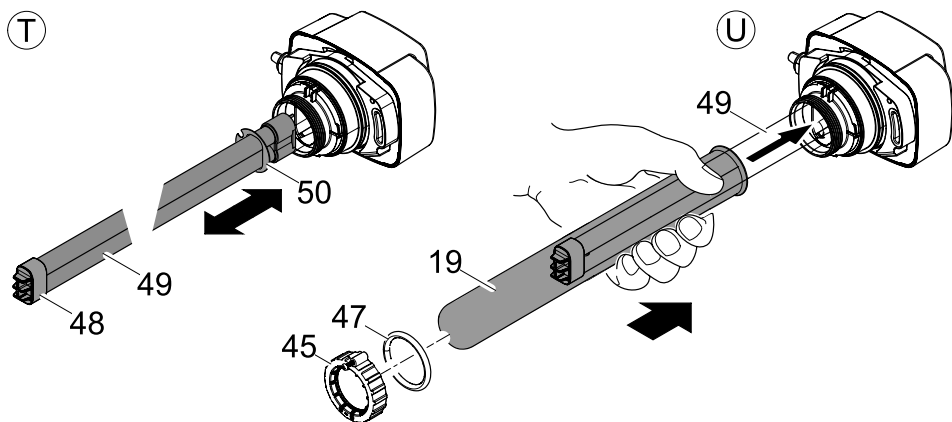
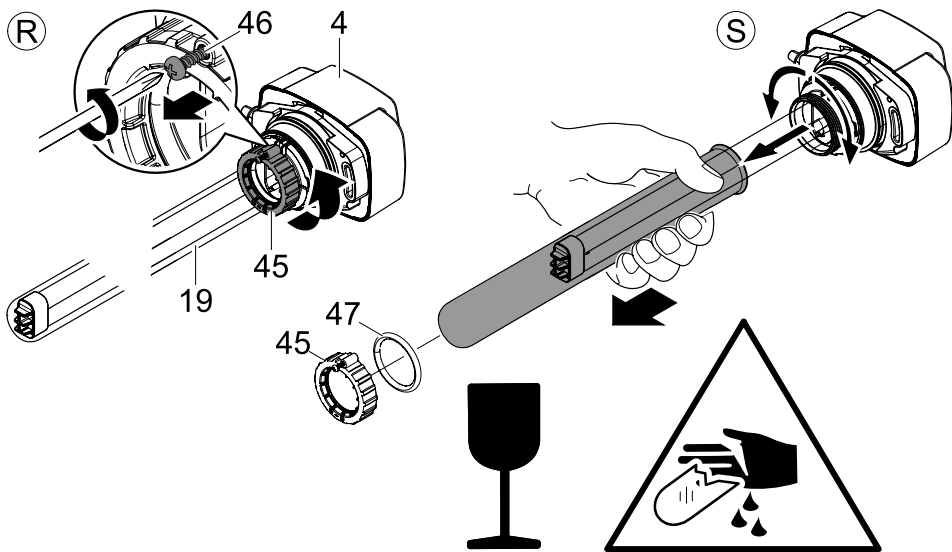

Translation of the original Operating Instructions

Information about these operating instructions

Welcome to OASE Living Water. You made a good choice with the purchase of this product **FiltoClear 12000/16000/20000/30000**.

Prior to commissioning the unit, please read the instructions of use carefully and fully familiarise yourself with the unit. Ensure that all work on and with this unit is only carried out in accordance with these instructions.

Adhere to the safety information for the correct and safe use of the unit.

Keep these instructions in a safe place! Please also hand over the instructions when passing the unit on to a new owner.

Symbols used in these instructions

The symbols used in this operating manual have the following meanings:

 **Risk of injury to persons due to dangerous electrical voltage**
This symbol indicates an imminent danger, which can lead to death or severe injuries if the appropriate measures are not taken.

 **Risk of personal injury caused by a general source of danger**
This symbol indicates an imminent danger, which can lead to death or severe injuries if the appropriate measures are not taken.

 Important information for trouble-free operation.

Scope of delivery

Figure (B)	Quantity	Description
	1	FiltoClear Pressure filter with UVC unit
	1	Connection material
20	2	Hose connector, transparent, 2"
21	2	Hose connector, transparent, 1 1/2"
22	1	Hose connector, black, 2"
23	1	Hose connector, black, 2", with thread
24	1	Hose connector, black, 1 1/2"
25	1	Hose connector, black, 1 1/2", with thread
26	3	Union nut
27	1	Flat sealing ring, black
28	2	Flow indicator flap, green
29	4	Hose clip

Intended use

FiltoClear 12000/16000/20000/30000, in the following termed "unit", and all other parts from the delivery scope may be used exclusively as follows:







- For mechanical and biological cleaning of garden ponds
- Operation under observance of the technical data.

The following restrictions apply to the unit:

- Never use the unit to filter fluids other than water.
- Never run the unit without water.
- Do not use for commercial or industrial purposes.
- Do not use in conjunction with chemicals, foodstuff, easily flammable or explosive substances.

Unit configuration and function description

Unit configuration

Figure (B)	Object	
1		Water return socket, for the return of filtered pond water
2		Water inlet socket, for the inlet of soiled pond water
3	Cleaning handle, the foam filters are compressed by pulling the handle up	
4	UVC unit head with temperature monitor, holder and control window for UV-C lamp. The UV-C lamp switches off automatically when overheated and on again once cooled down.	
5	Function switch to reverse the water flow. Turn counter-clockwise. 3 positions are available.	
		I: Water filtering and radiation
		II: Foam cleaning („Easy-Clean Technology“)
		III: Flushing the UVC unit and the UVC water housing
6	Bypass, optimises the UVC radiation effect at a high flow rate	
7		Soiled water drain socket, to drain the soiled water
8	Filter lid	
9	Cover cap, with black flat sealing ring inserted	
10	Clamping ring to hold filter lid and container together	
11	Step, marking the maximum installation depth	
12	Container, pressurised when the unit is in operation (max. 0.2 bar)	
13	Fine foam filter for nitrification and denitrification	
14	Coarse foam filter for nitrification	
15	Fixing disk, holding foam filters on cleaning rods	
16	Cleaning rod, connecting cleaning handle and filter disk	
17	Meshed tube, maintaining the foam filter spacing to the UVC water housing	
18	UVC water housing, conveying water to the UVC unit	
19	Quartz glass tube with UV-C lamp	

Function description

Figure (A)

A filter pump (only contained as a set in the scope of delivery) presses the water into a pressure-tight container, where it passes several cleaning stages before returned into the pond. The soiled water resulting from cleaning the unit can be used to fertilise the garden.

Figure B

Cleaning stage "filtering": The water flows through the foam filters. Mechanical soiling is retained by the foam filters. Suspended matter and bio sludge settle on the container bottom. Useful bacteria settle on the foam filters, cleaning the water biologically. Their effect starts at a water temperature of + 10 °C.

Coarse foam filters (blue)	Fine foam filters (red)
high flow rate	low flow rate
Bacteria for nitrification	Bacteria for nitrification and denitrification
Ammonia -> nitrite -> nitrate reaction	Nitrate -> nitrogen reaction

Cleaning stage "radiation": The water is radiated with the ultra-violet light from a UV-C lamp. Green algae die, pathogenic agents are killed.

Bypass: A bypass ensures that only part of the returning water (approx. 25 %) is radiated. In this manner a sufficient radiation duration is obtained even at a high circulation rate.

Filter starter: The unit only reaches its full biological cleaning effect after a few weeks. The formation of a bacterial community on the foam filters can be notably accelerated by adding filter starter bacteria.

OASE recommend:

- as a filter starter: OASE BioKick.
- as a reference value for the fish population in the pond: approx. 60 cm fish length in 1 m³ pond water.
- as a pond pump for FiltoClear 12000: Aquamax Eco 8000.
- as a pond pump for FiltoClear 16000: Aquamax Eco 10000.
- as a pond pump for FiltoClear 20000: Aquamax Eco 12000.
- as a pond pump for FiltoClear 30000: Aquamax Eco 16000.

Safety information

Hazards to persons and assets may emanate from this unit if it is used in an improper manner or not in accordance with its intended use, or if the safety instructions are ignored.

This unit can be used by children from the age of 8 and by persons with physical, sensory or mental impairments or lack of experience and knowledge, as long as they are supervised or instructed on how to use the unit safely and are able to understand the potential hazards. Do not allow children to play with the unit. Do not allow children to clean or maintain the unit without close supervision.

Hazards encountered by the combination of water and electricity

- The combination of water and electricity can lead to death or severe injury from electrocution, if the unit is incorrectly connected or misused.
- Prior to reaching into the water, always switch off the mains voltage to all units used in the water.

Correct electrical installation

- Electrical installations must meet the national regulations and may only be carried out by a qualified electrician.
- A person is regarded as a qualified electrician, if, due to his/her vocational education, knowledge and experience, he or she is capable of and authorised to judge and carry out the work commissioned to him/her. This also includes the recognition of possible hazards and the adherence to the pertinent regional and national standards, rules and regulations.
- For your own safety, please consult a qualified electrician.
- The unit may only be connected when the electrical data of the unit and the power supply coincide. The unit data is to be found on the unit type plate or on the packaging, or in this manual.
- Ensure that the unit is fused for a rated fault current of max. 30 mA by means of a fault current protection device.
- Extension cables and power distributors (e. g. outlet strips) must be suitable for outdoor use.
- Minimum safety distance between the unit and the water: 2 m.
- Ensure that the power connection cable cross section is not smaller than that of the rubber sheath with the identification H05RN-F. Extension cables must meet DIN VDE 0620.
- Protect the plug connections from moisture.
- Only plug the unit into a correctly fitted socket.

Safe operation

- Never operate the unit if either the electrical cables or the housing are defective!
- Do not carry or pull the unit by its electrical cable.
- Route cords/hoses/lines in a way that they are protected against damage, and ensure that they do not present a tripping obstacle.
- Only open the unit housing or its attendant components, when this is explicitly required in the operating instructions.
- Only execute work on the unit that is described in this manual. If problems cannot be overcome, please contact an authorised customer service point or, when in doubt, the manufacturer.
- Only use original spare parts and accessories for the unit.
- Never carry out technical modifications to the unit.

- The power connection cables cannot be replaced. When the cable is damaged, the unit or the component needs to be disposed of.
- Only operate the unit if no persons are in the water!
- The unit, the connections and plugs are not water-proof and must not be routed or installed in water.
- Keep the socket and power plug dry.

Symbols on the unit

The warning symbols on the unit have the following meaning:



Risk of personal injury if used incorrectly

Incorrect use of the unit can cause injury or damage to assets. Always read the instructions for use first.



Risk of personal injury caused by a general source of danger

Dangerous UVC radiation. Health hazard for eyes and skin caused by light flash. Only operate the UV-C lamp inside the housing.

The symbols on the unit relating to its use have the following meaning:

IP 24

Protected against touching dangerous components. Splash water protected.



Protect from direct sun radiation.



Dismantle at temperatures of 0 °C and below.

Installation

Figure (A)

To be taken into consideration for planning:

- Spacing between unit and water: min. 2 m (safety spacing!).
- Do not expose the unit to direct sun radiation.
- Water return point. OASE recommend: Route the return hose such that the clean water is indirectly returned to the pond, e.g. through a water course. In this manner it will be additionally enriched with oxygen.
- Height difference between filter lid and water return point: max. 2 m.

Installation possibility 1: Bury close to the pond.

Dig a hole close to the pond and place the container into the hole up to the mark (B 11).

Installation possibility 2: Placement close to the pond.

Place the unit close to the pond where it is flood protected (e.g. hidden behind shrubs). The ground must be firm and level.

Connecting a filter pump

A filter pump is required to operate the pressure filter (only contained as a set in the scope of delivery). Only connect to the pump by means of pressure hoses approved for at least 0.2 bar or the maximum pump pressure.

Hoses with an internal diameter of 1 1/2" or 2" can be connected to the unit.



Installation

Figure (C)

1 ½" hoses or 2" hoses can be connected to the unit. The respective hose connectors are part of our scope of delivery. Recommendation: Use 2" hoses to convey the water through the lines at a minimum pressure loss.

If you use a filter starter, fill the product into the container prior to carrying out the following installation steps (→Commissioning/Start-up).

Fitting the water inlet

How to proceed:

- Push the union nut (26) over the black hose connector (22).
- Insert the flat sealing ring (27) in the union nut (26).
- Screw tighten the hose connector to the water inlet socket (2) using the union nut.
- Push the hose clip (29) over the hose (30).
- Push the hose over the hose connector (up to the stop) and secure using the hose clip.

Fitting the water return

How to proceed:

- Push the union nut (26) over the transparent hose connector (20).
- Place the flow indicator flap (28) into the union nut.
- Screw tighten the hose connector to the water return socket (1) using the union nut.
- Push the hose clip (29) over the hose (30).
- Push the hose over the hose connector and secure with the hose clip. Leave the last segment free for use as a window to control flow and soiling (D).

Fitting the soiled water drain

The soiled water resulting from cleaning the unit can be used for fertilisation purposes. Recommendation: Connect and route a drain hose (not included in our scope of delivery) up to a suitable point (e.g. plant bed).

How to proceed:

- Unscrew the cover cap (9) from the soiled water drain socket (7).
- Push the union nut (26) over the transparent hose connector (20).
- Place the flow indicator flap (28) into the union nut.
- Screw tighten the hose connector to the socket using the union nut.
- Push the hose clip (29) over the hose (30).
- Push the hose over the hose connector and secure with the hose clip. Leave the last segment free for use as a window to control flow and soiling (D).

Closing the soiled water drain



Note!

During filter operation, ensure that the soiled water socket (7) or a drain hose (30) connected to it is always closed with a cover cap (9) with the flat sealing ring inserted. This prevents unintended emptying of the pond.

How to proceed:

- Push the hose clip (29) over the hose (30).
- Push the hose connector (23) into the hose and secure with the hose clip.
- Close the hose connector using the cover cap with the flat sealing ring (9) inserted.

Commissioning/start-up



Attention! Sensitive electrical components.

Possible consequence: The unit will be destroyed.

Protective measure: Do not connect the unit to a dimmable power supply.

OASE recommends the use of **BioKick** (OASE filter starter bacteria):

- For the initial start-up
- After manual cleaning of the foam filters
- After fitting new foam filters
- When recommissioning following a storage period/over-wintering

Prior to using filter starter bacteria ("Filter starter"), operate the unit for approx. 24 hours without switching on the UVC unit. If you do not use filter starter bacteria, commissioning can start directly with the "Fitting connections" step.

How to proceed:

- Open the container (→Cleaning and maintenance\Opening the container).
- Fill the filter starter bacteria (adhere to the attendant instructions for use!).
- Close the container (→Cleaning and maintenance\Closing the container).
- Fit the connections (→ Assembly).
- Check the firm seating of hoses, cover cap for soiled water drain, clamping ring with safety latch.
- Turn the function switch (J 5) to water filtering (40), if it is not already in this position.
- Switch on the pond pump.
- Only switch on the UVC unit when water is flowing through it. You may have to wait for 24 hours. Connect power plug to the socket. The UVC unit switches on immediately, the blue LED (J 33) is lit.

Operation

The unit is no longer biologically active at water temperatures below 10 °C. Take the unit out of operation at water temperatures below 8 °C or, at the latest, when freezing temperatures are to be expected.

Normal operating condition: The UVC unit is switched on. The UV-C lamp must be replaced after approx. 8000 operating hours.

Remedy of faults

Malfunction	Cause	Remedy
No water flow through the return socket.	- Filter pump not switched on.	- Switch on the filter pump
	- Supply lines blocked.	- Check supply lines
	- Function switch not turned to "Filter water"	- Turn function switch to „Filter water“
UVC lamp display is not lit	- Connection defective or has not been made.	- Check connection (power plug, power fuse)
	- Temperature monitor has switched off the UVC lamp	- Allow the UVC lamp to cool down
	- UVC lamp defective	- Replace UVC lamp
	- Quartz glass tube not fitted	- Fit quartz glass tube
Filtering performance not satisfactory	- Function switch not turned to "Filter water"	- Turn function switch to „Filter water“
	- Unit has not been in operation long enough	- Wait a few days/weeks
	- Water extremely soiled	
	- Excessive fish and animal population	- Adhere to the reference value
	- Foam filters clogged	- Clean foam filters
	- Quartz glass tube soiled	- Cleaning the quartz glass tube
- UVC lamp is in operation for more than 8000 hours	- Replace UVC lamp	

Wear parts

The UVC lamp, the quartz glass and the foam filters are wear parts and are excluded from the warranty.



Maintenance and cleaning

Removing/inserting the UVC unit head



Attention! Dangerous electrical voltage.

Possible consequences: Death or severe injury.

Protective measures: Switch off the mains voltage prior to carrying out work on the unit.

Removing the UVC unit head

Figure (E)

How to proceed:

- Press the blue "Press" button (31) at the UVC unit head (4).
- Slightly turn the UVC unit head counter-clockwise.
- Carefully pull the UVC unit head out of the filter lid (8).

Inserting the UVC unit head

Figure (F)



Note!

The O ring (32) on the closure of the UVC water housing (4) is firmly clamped on. Only remove the O ring when it must be replaced (e.g. when the O ring is porous).

How to proceed:

- Carefully insert the UVC unit head (4) into the filter lid.
- Turn the UVC unit head clockwise up to the stop.
- The blue "Press" button engages (31).

Opening/ closing the container



Attention! Dangerous electrical voltage.

Possible consequences: Death or severe injury.

Protective measures: Switch off the mains voltage prior to carrying out work on the unit.

Opening the container

Figure (G)

How to proceed:

- Push back safety latch (36).
- Press the closing hook (35) inwards.
- Open and remove the clamping ring (10).

Closing the container

Figure (H, I)

How to proceed:

- Clean the channel (H 37) around the container rim.
- Grease the lid sealing ring (34) and place flush around the container (38) top edge.
- Press the filter lid (I 8) including the stack of foam filters on the container, if necessary, assist with your own body weight.
- Place the clamping ring (10) around the container top edge (do not pinch the power cable) and assemble.
- Engage the closing hook (35).
- Push in the safety latch (36).

Cleaning the foam filters

The Easy-Clean function (actuate the cleaning handle and flush with water) allows easy cleaning of foam filters, UVC unit and UVC water housing.

Figure (J, K, L)

How to proceed:

- Remove the closing cap from the drain hose or the dirty water drain socket (K 7). Attention: Do not lose the sealing ring in the cap!
- Turn the function switch (5) counter-clockwise to "Cleaning foam filters" (41).

- Vigorously pull up the cleaning handle (3) several times, then push the handle down against the stop ("pumping" action).
The foam filters will be rinsed by this action.
- As soon as only clean water appears in the transparent hose connector (20), turn the function switch (5) counter-clockwise to "Cleaning UVC" (L 42).
The UVC unit and the UVC water housing are flushed.
- As soon as only clean water appears in the transparent hose connector (20), turn the function switch (5) counter-clockwise to "Filter water" (J 40).
The unit filters the pond water.
- Close the drain hose or the soiled water drain socket (7) using the closing cap (insert sealing ring!) (C 9).

Cleaning the quartz glass tube manually

Figure (E, F)



Attention! Dangerous electrical voltage.

Possible consequences: Death or severe injury.

Protective measures: Switch off the mains voltage prior to carrying out work on the unit.

How to proceed:

- Switch off the filter pump.
- Remove the UVC unit head (→Cleaning and maintenance\Removing/inserting the UVC unit head).
- Check the quartz glass tube (F 19) and O ring (32) for damage. Replace, if necessary.
- Clean the quartz glass tube externally using a moist cloth.
- Insert the UVC unit head (→Cleaning and maintenance\Removing/inserting the UVC unit head).
- Switch on the filter pump.
- Switch on the UVC unit.

Cleaning the unit and washing or replacing the foam filters

Wear of the foam filters is caused by mechanical stress and normal ageing. OASE recommend: Replace old foam filters with new ones at the beginning of the new season.

Figure (M, N, O)



Attention! Dangerous electrical voltage.

Possible consequences: Death or severe injury.

Protective measures: Switch off the mains voltage prior to carrying out work on the unit.

How to proceed:

- Switch off the filter pump.
- Remove all hoses, hose connections (M).
- Remove the UVC unit head (4) (→Cleaning and maintenance\Removing/inserting the UVC unit head).
- Open the container (→Cleaning and maintenance\Opening the container).
- Remove the lid including the stack of foam filters (N 39) and place on a soft clean surface such that the fixing disk (15) of the stack of foam filters faces upward.

Disassembling the foam filters

- Check the foam filters, and either wash or replace.
- Remove the filter disk (N 15) after loosening and removing the two screws (43).
- Pull off the foam filters.

Cleaning the parts

Figure B

- Clean the container, clamping ring, lid (remove UVC unit head!) including UVC water housing (18) and the meshed tube (17) from all angles with a strong water jet.
- If necessary, wash the foam filters individually by vigorously compressing and releasing the filters under running water.

Assembling the foam filters:

Figure (P, Q)

- Alternately push the blue (14) and then the red (13) foam filter onto the cleaning rods (16), so that the cleaning rods rest in the two cut-outs.
- Place the fixing disk (15) on the last foam filter such that the end collar (44) points to the foam filters.
- Fasten the fixing disk on the cleaning rods using the two screws (Q 43).
- Reinstall all connections (→ Assembly).



Replacing the UVC lamp



Attention! Dangerous electrical voltage.

Possible consequences: Death or severe injury.

Protective measures: Isolate the unit prior to reaching into the water and carrying out any work on the unit. Secure the unit from being switched on inadvertently.



Attention! Breakable glass.

Possible consequences: Injury of your hands caused by cuts.

Protective measures: Handle both quartz glass and UVC lamp with care.



Note!

- Condensate forms in the quartz glass tube. This condensate cannot be avoided, however, it does not impair function and safety.
- The quartz glass tube can become scratched or blind over time. In this case, sufficient cleaning performance of the UVC lamp is no longer guaranteed. The quartz glass tube must be replaced.
- The UVC lamp must be replaced after approx. 8000 operating hours. Only use UVC lamps the designation and rating of which match the information on the type plate.

Figure (R, S, T, U, V)

How to proceed:

- Remove the UVC unit head (→Removing/inserting the UVC unit head).
- Clean the quartz glass tube (R 19) externally using a moist cloth.
- Undo the fastening screw (46) from the retaining ring (45), and unscrew the retaining ring.
- Remove the quartz glass tube including the O ring (S 47).
- Pull the UVC lamp (T 49) out of the lamp base.
- Pull the transport securing elements (48 and 50) from the UVC lamp and push over the new UVC lamp.
- Insert the new UVC lamp.
- Place the quartz glass tube (U 19) over the UVC lamp (49) again.
- Push the O ring (47) and the retaining ring (45) over the quartz glass tube.
- Tighten the retaining ring by turning it up against the stop (51).
- Tighten the fastening screw (46) for the retaining ring (V).
- Reinsert the UVC unit head (→Removing/inserting the UVC unit head).
- Switch on the pond pump.
- Connect the power plug of the UVC unit.

Decommissioning/Storage/Over-wintering

- Empty/drain the container, hoses and connections as much as possible.
- Clean thoroughly and check the unit for damage.
- Remove, clean, and store the filter lid with the UVC unit and all filter elements in a dry and frost-free place.
- Ensure that the storage place is inaccessible to children.
- Secure the installation place of the buried container such that it does not pose any risk of accident for persons or animals.

Disposal

Support us in our endeavour to keep our environment intact, and adhere to the following disposal information!

 Use our return system for disposal. Always make electrical units unusable by cutting the cables!	Disposal with the household waste:
UVC unit (electronics!)	Packaging
UVC lamp (mercury!)	Worn foam filters, sealing rings
	Filter container

Technische Daten

DE	Type	Abmessungen	Gewicht	Bemessungsspannung	Leistungsaufnahme	Kabellänge	Anschlüsse	Filtervolumen	UV-C-Lampe	max. Teichvolumen	Wassertemperatur
GB	Type	Dimensions	Weight	Rated voltage	Power consumption	Cable length	Connections	Filter volume	UV-C lamp	max. pond volume	Water temperature
FR	Type	Dimensions	Poids	Tension de mesure	Puissance absorbée	Longueur de câble	Raccordements	Volume de filtration	Lampe UVC	Volume max. de l'étang.	Température de l'eau
NL	Type	Afmetingen	Gewicht	Dimensioneringsspanning	Vermogensopname	Kabelingte	Aansluitingen	Filtervolume	UVC-lamp	max. vijvervolume	Wattentemperatuur
ES	Tipo	Dimensiones	Peso	Tensión asignada	Consumo de potencia	Longitud del cable	Conexiones	Volumen de filtro	Lámpara UVC	Volumen máximo del estanque	Temperatura del agua
PT	Tipo	Dimensões	Peso	Voltagem considerada	Potência absorvida	Comprimento do cabo	Conexões	Volume do filtro	Lâmpada UVC	Volume máximo do lago de jardim	Temperatura da água
IT	Tipo	Dimensioni	Peso	Tensione di taratura	Potenza assorbita	Lunghezza cavo	Allacciamenti	Volume di filtraggio	Lampada UVC	Volume max. del laghetto	Temperatura dell'acqua
DK	Type	Dimensioner	Vægt	Nominal spænding	Effektforbrug	Led- længde	Tilslutninger	Filtervolumen	UVC-lampe	maks. damnvolumen	Vandtemperaturen
NO	Type	Mål	Vekt	Merkespenning	Effektoptak	Kabel lengde	Tilkoblinger	Filtervolum	UV-lampe	maks. damnvolum	Vanntemperatur
SE	Type	Mått	Vikt	övre märkspänning	Effekt	Kabellängd	Anslutningar	Filtervolyum	UVC-lampa	max. damnvolyum	Vattentemperatur
FI	Tyyppi	Mitat	Paino	mitoitustasante	Tehonotto	Kaapelin pituus	Liitännät	Suodatusliivavuus	UVC-lamppu	Altaan max. tilavuus	Veden lämpötila
HU	Típus	Méreték	Súly	mért feszültség	Teljesítményfelvétel	Kábelhossz	Csatlakozók	Szűrési térfogat	UVC-lámpa	max. tó térfogat	Víz hőmérséklet
PL	Typ	Wymiary	Ciepzar	napięcie znamionowe	Pobór mocy	Długość kabla	Przyłącza	Objętość filtra	Lampa ultravioletowa	maks. pojemność stawu	Temperatura wody
CZ	Typ	Rozměry	Hmotnost	domezovací napětí	Přikon	Délka kabelu	Připojky	Objem filtru	UVC zářivka	max. objem jezírka	Teplota vody
SK	Typ	Rozměry	Hmotnost	dimenziončné napätie	Přikon	Dĺžka kábla	Pripojky	Objem filtra	UVC žiarivka	max. objem záhradnej nádrže	Teplota vody
SI	Tip	Dimenzije	Teža	dimenzionirana napetost	Poraba moči	Dolžina kabla	Priključki	Volumen filtra	UVC-žarnica	maks. prostornina ribnika	Temperatura vode
HR	Tip	Dimenzije	Masa	gornji nazivni napon	Potrošnja energije	Duljina kabela	Priključci	Zapremina filtra	UVC žarulja	maks. obujam jezera	Temperatura vode
RO	Tip	Dimensiuni	Masă	tensiunea măsurată	Pulare consumată	Lungime cablu	Conexiuni	Volumul filtrului	Lampă cu ultraviolet	max. volum iaz	Temperatura apei
BG	Тип	Размери	Тегло	номинално напрежение	Потребявана мощност	Дължина на кабелите	Връзки	обем на филтъра	Уltravioletова лампа	макс. обем на езерото	Температурата на водата
UA	Тип	Розміри	Вага	розрахункова напруга	Споживання електроенергії	Довжина кабелю	Підключення	Об'єм фільтра	UVC-лампа	макс. об'єм ставка	Температура води
RU	Тип	Размеры	Вес	расчетное напряжение	Потребление мощности	Длина кабеля	Соединения	Объем фильтра	Коротковолновая УФ-лампа	макс. объем пруда	Температура воды
CN	型号	尺寸	重量	设计电压	耗功率	电缆长度	连接体积	过滤体积	紫外线灯	最大池塘容量	水温
FiltroClear	12000	380 x 510 mm	6.9 kg	~ 220 - 240 V, 50/60 Hz	18 W	5 m	1½" - 2"	13.5 l	18 W TC-L(UV-C)	12 m³	min. +8 °C max. +35 °C
	16000	380 x 630 mm	7.6 kg		24 W			24 W TC-L(UV-C)	16 m³		
	20000	380 x 750 mm	8.5 kg		36 W			36 W TC-L(UV-C)	20 m³		
	30000				55 W			55 W TC-L(UV-C)	30 m³		

FiltroClear				
Pos.	12000	16000	20000	30000
A	21377	21378	21650	21650
B	21294	21299	15999	16000
1	15830	15830	15830	15830
2	25993	25993	25993	25993
3	34578	34578	34578	34578
4	24461	24462	26527	26527
5	51255	51258	51290	51290
6	15956	15956	15956	15956
7	21539	21539	21539	21539
8	16033	16033	16033	16033

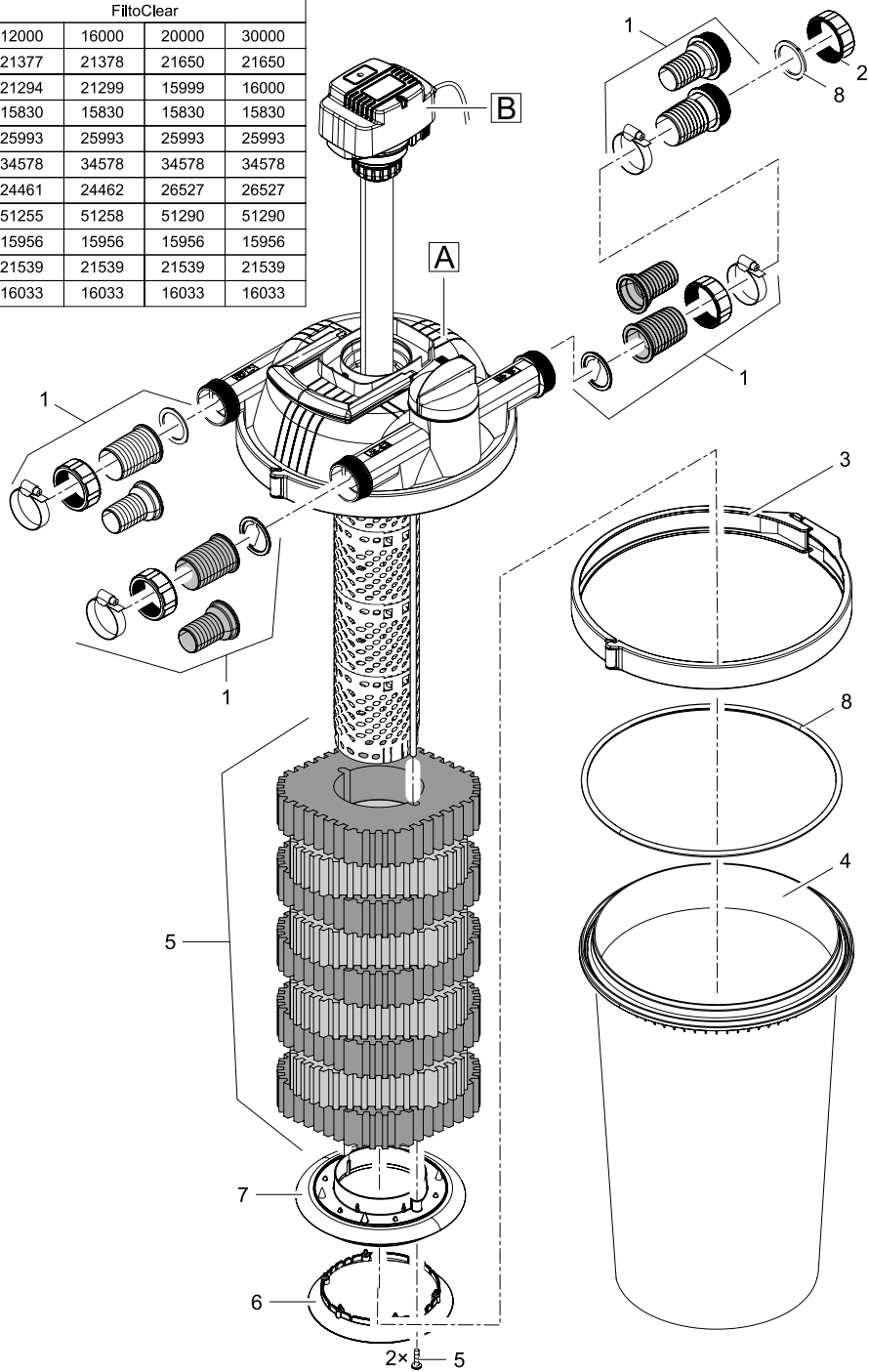

FiltroClear				
Pos.	12000	16000	20000	30000
A	21377	21378	21650	21650
9	16029	16029	16029	16029
10	16064	16064	16064	16064
11	21653	21654	21655	21655
12	24748	24747	26596	26596

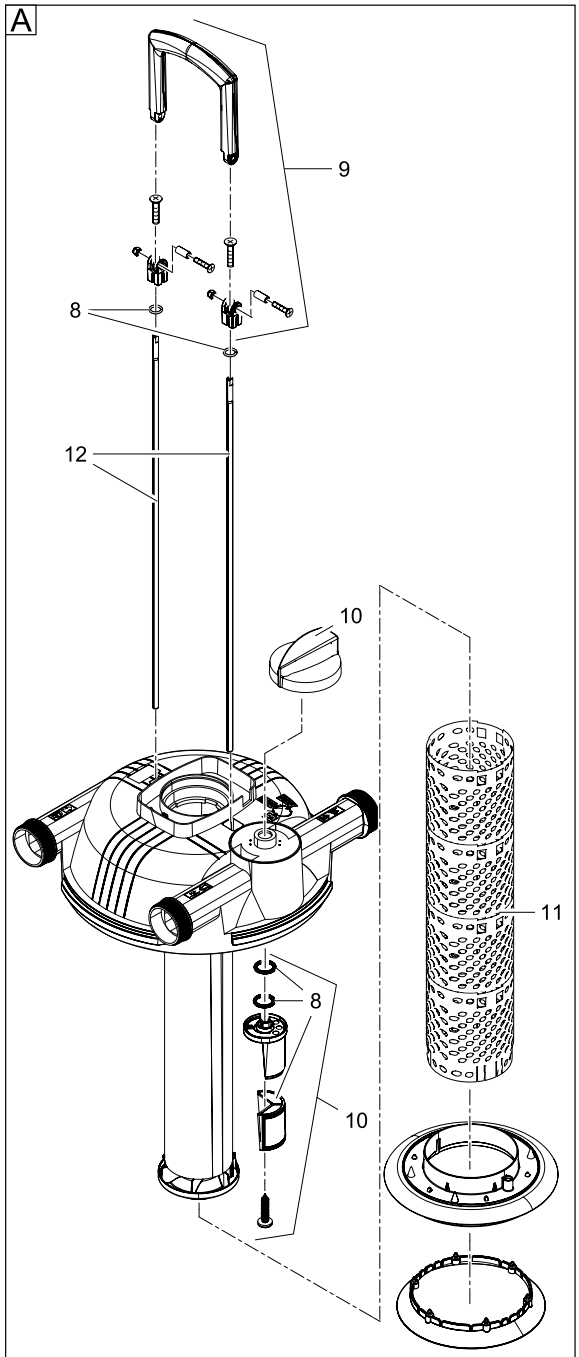

Pos.	FitoClear			
	12000	16000	20000	30000
B	21294	21299	15999	16000
13	21303	21308	15536	15533
14	56236	56237	55432	56636
15	13332	21763	13331	13331
16	16031	16031	16031	16031

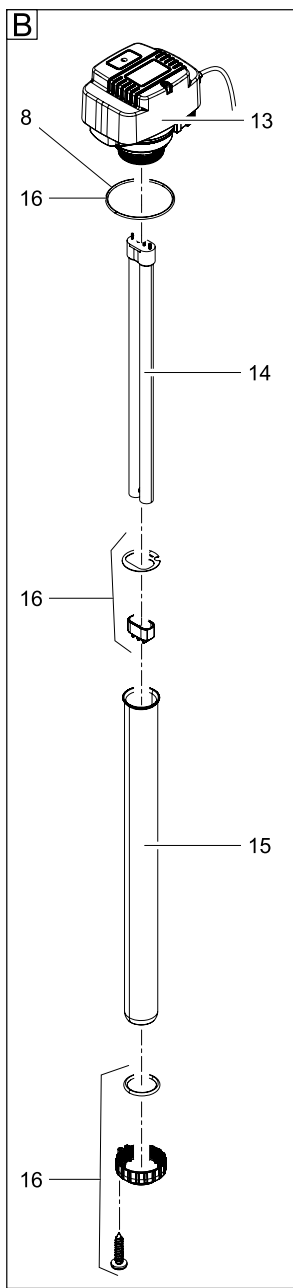



OASE GmbH · www.oase-livingwater.com

Tecklenburger Straße 161 · 48477 Hörstel · Postfach 20 69 · 48469 Hörstel · Germany



21525/07-13